



Series  
NSX

T-CAS - SIZE 1 RF CONTACT  
RG 142 - RG 400 - TIMES AA 6343 - ECS 3C142B ASNB-E 0293 XF CABLE  
CRIMP TERMINAISON

Issue:  
09 DEC 96

Page  
1 / 1

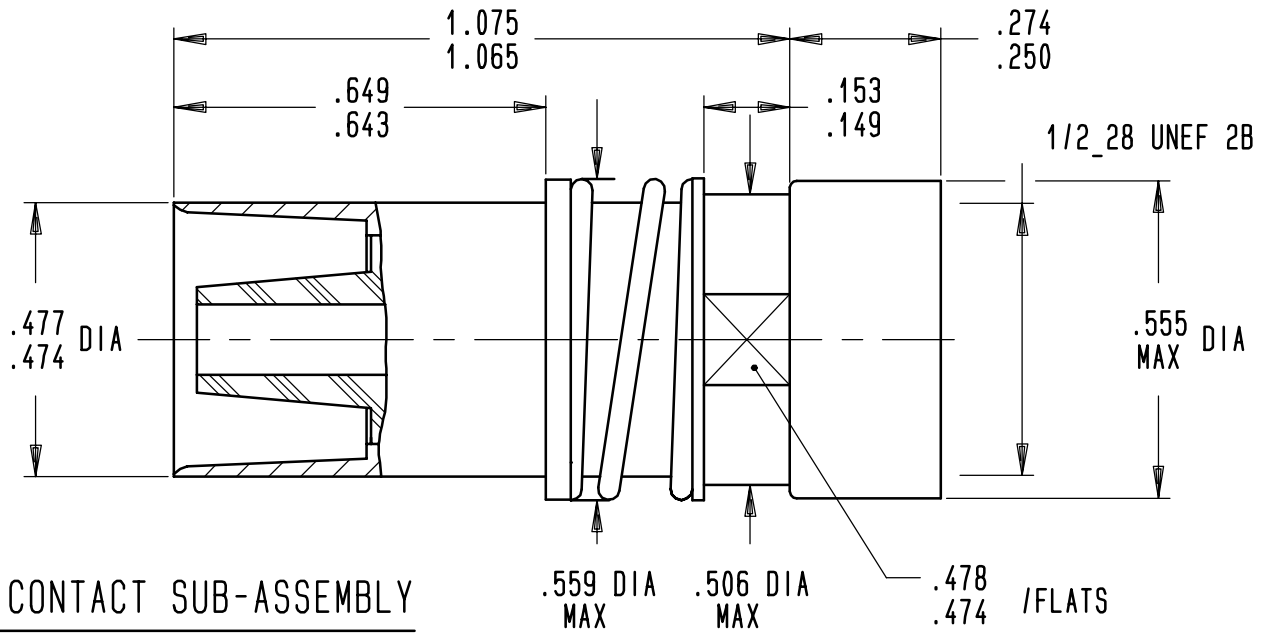

OUTER CONTACT SUB-ASSEMBLY

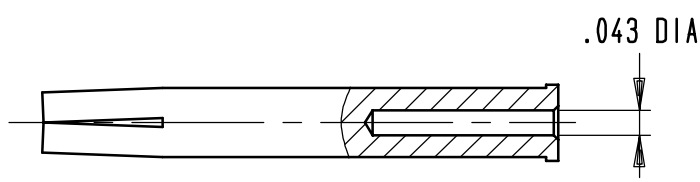

CENTER SOCKET CONTACT

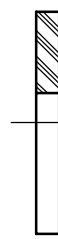

DIELECTRIC WASHER

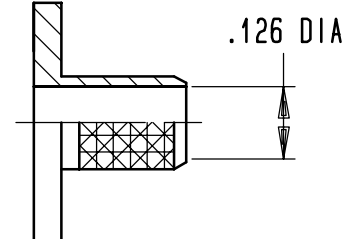

CRIMP SLEEVE

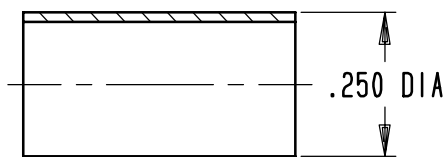

FERRULE

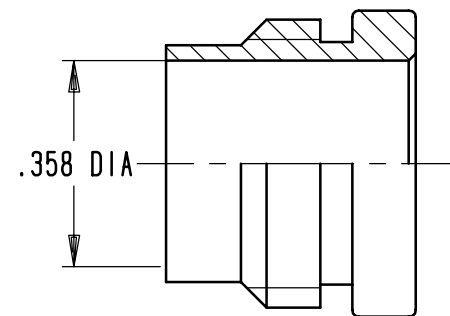

CLAMP NUT

MATERIAL AND FINISH

CONTACT PARTS : COPPER ALLOY- .00005 INCH OF GOLD OVER NICKEL  
SPRING: STAINLESS STEEL  
C.CLIP: STEEL - NICKEL PLATED  
WASHER: STAINLESS STEEL - PASSIVATED  
DIELECTRIC AND DIELECTRIC WASHER: TEFLON

WIRING INSTRUCTIONS : RP 6178

4112-9610

CREATION				
PEN: .				
NOM: FALETTI				
DATE: 19 SEPT 90	09 DEC 96	REDRAWN	VALGRESY	.
APPR.: .	Issue	Revisions	Name	Approved